

This additional HowTO information should be used when installing any CS FOR DOORS product that incorporates the **CornerMeeting** Detail Option.

CornerMeeting™

CornerMeeting detail applies to **CS CavitySliders** and **CS TrackSystems** only.

In all cases, one door (the leading door) will overlap the other door (the trailing door). See diagram 1.

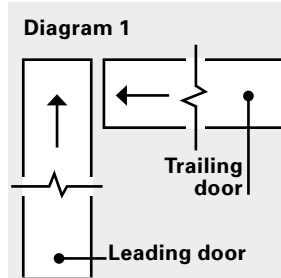

Single track CornerMeeting detail showing carriage access slot and Bi-Parting door stops.



Installation Notes

- Standard Bi-Parting Installation Instructions should be followed for the majority of the installation.
- Front mounting plate position (diagram 2): 150mm from edge.
- Units are supplied with mitre aids fitted to one track.*
Install the first unit then slide the second track into position over the mitre aid (diagram 3).
AluSealed units are also supplied with polyethylene mitre aids. Fix these place using the #8 x 19mm screws supplied (diagram 4).
- Check floor clearances as doors are sliding in opposing planes and may be affected by uneven floors. Pack underneath the bottom plate where required.

View looking up at examples of various CS CornerMeeting track configurations

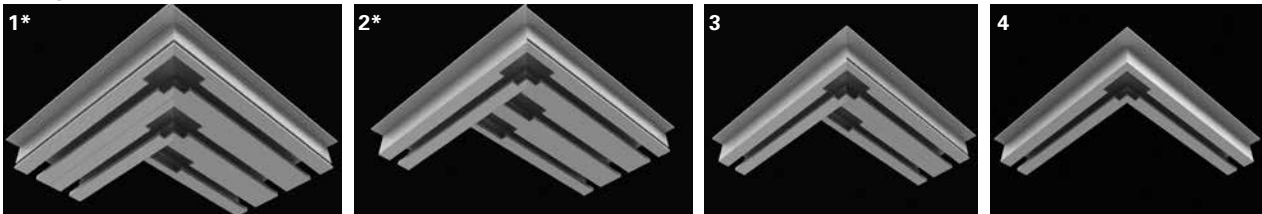

Disclaimer: CS FOR DOORS recommends the use of **CS NewYorker** or **CS AluTec** doors when using this detail for the following reasons:

- Aluminium door leaves are straight, ensuring a neat overlap join when tracks are installed correctly on site.
- Magnets may be hidden within the aluminium door stiles for a positive closing action.

* Note: mitre aid does not fit triple track.

© CS FOR DOORS and CS Cavity Sliders are Registered Trademarks. New Zealand Patent No: 533838. All copyright and other property in this document is reserved by Cavity Sliders Limited. Details and specifications are subject to change without notice. Whilst all care is taken to ensure the accuracy of all information, no responsibility will be accepted for any errors or omissions.

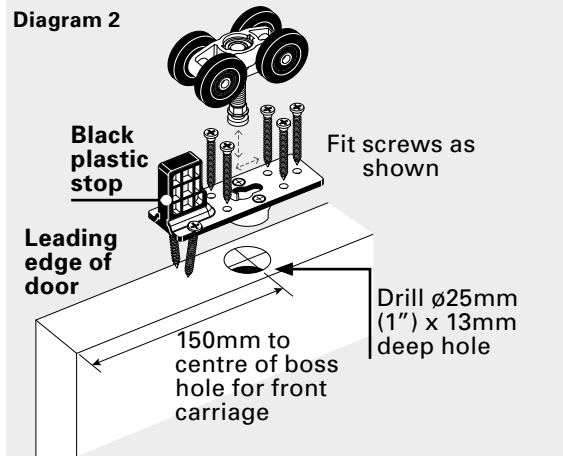

CornerMeeting Track Assembly Detail

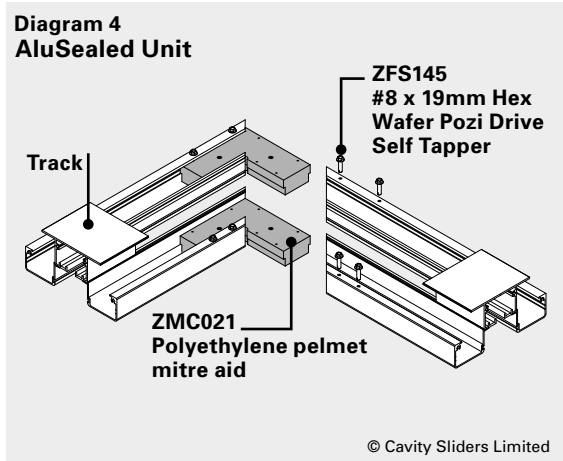
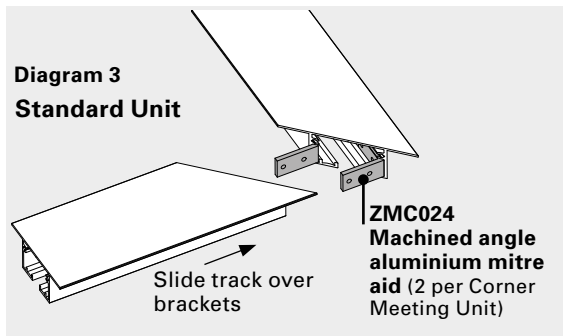

© Cavity Sliders Limited

Another quality product from: